



Contact the Flooring Specialist

 +971 4 347 0460

 [uae@flowcrete.com](mailto:uae@flowcrete.com)

## How to Avoid Screed Failure

---

Screeds provide a vital layer in a floor that bonds the finish people see and walk across to the concrete substrate of the building's construction.

If properly applied and maintained then most screeds need never be seen until the building comes to the end of its life and is dismantled. However failures in the planning, application, curing or drying processes can lead to later, potentially very costly, problems.

---

### Why Install a Screed?

Screeds are required when a colourful or functional floor is needed rather than a bare concrete surface. For industrial purposes, or commercial locations which will undergo frequent traffic, a more robust screed is required than is used in residential projects.

Most screeds are used for internal purposes only, often covering heating systems, acoustic or thermal insulation. Polymer-modified screeds can be installed in external locations as they are hard-wearing, water resistant and able to withstand a more rigorous environment.

Traditionally screeds are sand and cement mixtures, blended and applied on site. However these are often unpredictable as the ratios and properties cannot be exactly determined and so can lead to a weak flooring layer liable to crack, peel or collapse without warning. To counter this unreliability Flowcrete has produced a

range of proprietary screeds with enhanced strength and a faster application speed that will react more predictably.

Generally speaking there are two types of screed, a semi-dry formula which is hand applied and then trowelled to a finish and a liquid, free-flowing mixture that is pumped to a prescribed depth.

Of these types there are several different identifiable screeds with different properties that will thrive or fail in various environments and can be applied in varying thicknesses:

- Modified Semi-Dry Cementitious
- Modified Self Levelling Cementitious
- Modified Self Levelling Non Cementitious
- Anhydrite
- Wearing Granolithic

|                                   | Traditional Sand & Cement | Proprietary                        | Anhydrite (Synthetic)        | Alpha Hemihydrate                   | Pumpable Cementitious        |
|-----------------------------------|---------------------------|------------------------------------|------------------------------|-------------------------------------|------------------------------|
| Drying time                       | 1 day per mm (at 75 mm)   | 1 week per 25 mm                   | 1 day per mm                 | 8 days per 10 mm                    | 24 hours                     |
| Curing Time (to following trades) | 7 days                    | 3 days                             | 2 days                       | 24 hours                            | 2-4 hours                    |
| Compressive Strength              | 20 N/mm <sup>2</sup>      | 30 N/mm <sup>2</sup> (B.S EN 4551) | 30 N/mm <sup>2</sup> in situ | 35 N/mm <sup>2</sup> (B.S EN 13892) | 30 N/mm <sup>2</sup> in situ |
| Sand:Cement                       | 6:1 or 5:1                | 4:1                                | N/A                          | N/A                                 | N/A                          |
| Shrinkage = Less shrinkage        | More water                | Less water                         | N/A                          | <0.4%                               | N/A                          |
|                                   |                           |                                    | Tested at 20°C and 65% RH    |                                     |                              |

FIGURE 1: Comparing Screed Types, Flowcrete Group Ltd, 2013.

Self-levelling screeds are applied in a liquid form which smooths itself out over a given area whilst the semi-dry version has to be levelled by hand or machine.

An advantage of semi-dry screeds is that they can be laid at an angle. This is useful for applications such as floors that need to slope to a drain or internal ramps.

Self-levelling screeds will usually arrive as a dry powder and have water added. They are very sensitive to the ratio of water used, too much and it will segregate and crack, too little and it won't level correctly.

The thickness of the layer will vary depending on the screed type and the load requirements of the floor. Thicker screeds will generally take longer to install due to an increased drying time, however fast drying systems can be utilised to avoid long delays to construction programmes.

Anhydrites provide an environmentally friendly, weight saving solution with minimal cracking and no curling able to be applied quickly. It has a

curing time of approximately two days compared to five days for a semi-dry cementitious system.

Flowcrete's innovative Isocrete K-screed is an award winning semi-dry cementitious screed which has a good reputation within the construction industry for combining high strength and excellent moisture control and a very quick installation turn around. The K-screed includes a plasticising and accelerating admixture called K-additive which modifies and enhances the screed performance.

### Installation

The method of installing a screed can vary depending on the requirements of the project. As a general rule architects and project managers can be assured of a long lasting screed so long as the right option is chosen and it is laid correctly.

Most screed failures arise from mistakes during installation, therefore it is important to have a good idea of this process to iron out potential problems.

There are five main forms of installation which are defined by the manner in which they bond to the concrete substrate. They can be categorised into either a bonded or an unbonded form. Bonded is less prone to shrinkage or cracking, however there are advantages to the unbonded system which includes being more effective at preventing moisture transfer, being more isolated from the building and easier to alter in the future.

These five application forms are:

- Bonded
- Unbonded
- Resin Bonded
- Floating
- Partially Bonded

### Floating Installation

Today most screeds are applied as floating screeds and have become increasingly popular because they can be placed on top of underfloor heating and insulation solutions, which have environmental and ecological benefits.

This method is termed floating because the screed is not applied to the base but is put on top of a separating membrane which will

be applied on top of the layer of underfloor heating or insulation. Unless a propriety screed is used this layer of screed requires a minimum of 75 mm coverage otherwise cracking will occur.

The insulation material needs to compress enough to withstand trafficking of the floor. If it is too weak then the insulation will compact too much and the screed will crack. It is important to know the strength of the insulation to know whether or not it will hold up to the screed chosen to go on top of it. The compression rate is the figure that needs to be checked against the loading to ascertain if the combination will work.

### Bonded Installation

A bonded screed means that it has been fixed directly onto the concrete underneath. Thicker screeds and self-levelling screeds in particular are usually applied using the bonded method. The first step in this process is to mechanically prepare the concrete to bond with the screed in a process called scabbling or shot blasting. This is a vital step which needs to be done to take off the weaker top surface of the concrete, as it is better for the screed to bond with the harder aggregates underneath.

**Floating Screed:**

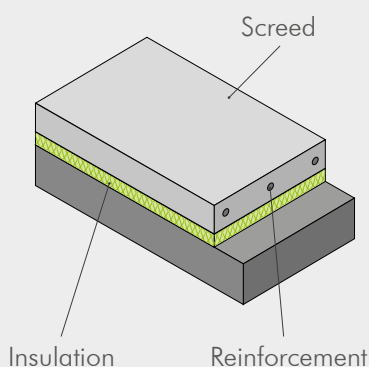

**Bonded Screed:**

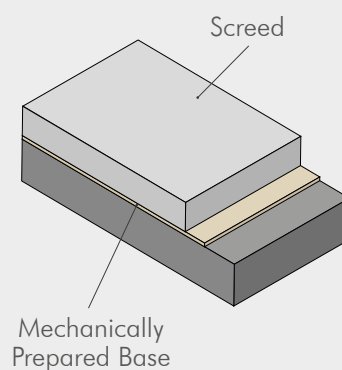

**Resin Bonded Screed:**

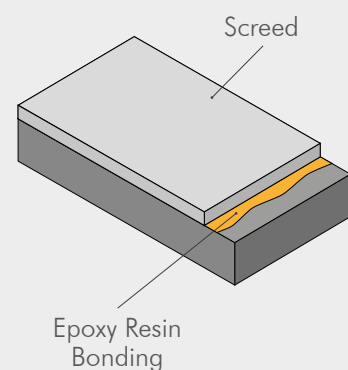

If the scabbling is not done, or is unsatisfactorily undertaken, then the screed bonds to a very weak layer which could cause the screed to debond and the floor to fail.

For the application of K-screed a primer needs to be put down first to kill the suction of the prepared concrete slab. If the primer is not applied then the concrete will suck the moisture out of the screed and it won't set properly. A wet bonding slurry is then laid down and the screed applied into the wet slurry grout.

### Resin Bonded

A resin bonded application may incorporate a damp proof membrane, utilising a resin layer to firmly fix the screed to the concrete base.

#### Unbonded Screed:

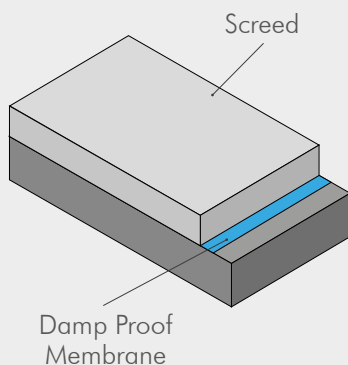

#### Partially Bonded Screed:

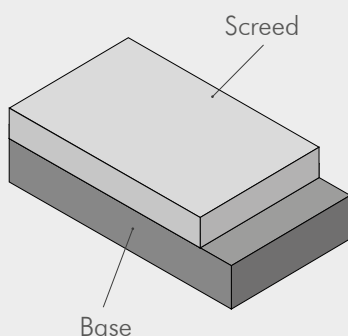

There are several key benefits to this including reducing the thickness of the screed to a 15 mm minimum and lowering the danger of cracking or curling without the need for reinforcement.

### Unbonded Installation

An unbonded installation is when a separating membrane, usually a polythene sheet, is placed between the concrete and the screed, usually because a damp proof membrane is required.

An unbonded installation may also be utilised to save resources, as the time and effort that would go into preparing the concrete is avoided. It could also be a solution if there is not enough space to bring in the machinery required to shot-blast the concrete.

This screed needs to be at least 50 mm thick unless a proprietary Flowcrete screed is used which can be thinner.

### Partially Bonded

Partially bonded screeds are not recommended by Flowcrete for industrial or commercial purposes as the finish is prone to cracking. In this form of application the screed is laid directly onto unprepared concrete and it cannot be guaranteed to achieve a bond across 100% of the area. You can tell where it hasn't bonded by tapping the dried screed and listening for a hollow sound, meaning it has not bonded.

### Floorzone

Failures can occur throughout the floor because of mistakes that arise when different contractors are brought in to complete different sections. For example if the company supplying the screed does not specify a strong enough product it will lead to compaction problems, or the resin floor finish supplier may not know the optimum method for binding to the chosen floor screed.

**TIP:**

Avoid costly repair work by ensuring substrates are properly prepared.

To minimise failure risks stemming from multiple companies working across each other Flowcrete offers the Floorzone solution which gives clients the ability to source every section of a floor from one place. This is an integrated, green-friendly concept that minimises risks and maximises results.

Flowcrete is able to work with construction managers to specify the ideal products and installation method to ensure the best floor possible. The client only needs to deal with one manufacturer who can project manage the consultation, specification, manufacture, logistics, installation, warranty and aftercare.

## Application Problems

Peeling or crumbling screeds are one of the biggest areas of litigation in construction and can stem from any one of a number of failures in the application process. Alongside these problems, sand pockets, hollow finishes, weakness, blistering, curling and debonding issues can all affect the screed at a number of points.

The potential for these problems to occur should not be overlooked as they could take a significant amount of time, money, resources and energy to put right.

## Specification

It's important to understand the requirements of your project and the viability of the different types of screeds and methods of application. The same solution should not be copied and pasted into a different scenario as the relevant individual factors of the project may not be the same.

Essential factors to consider include the projects scale, budget, environmental impact, insulation, construction schedule, durability requirements and development constraints. For example an operating theatre or workshop area will need a heavy duty system whereas an office room will likely require a light duty screed.

The planning process is vital to making sure the screed does not fail, as if the wrong screed is chosen, the wrong thickness applied or the wrong installation method used then a whole range of failures and problems are likely to occur.

## Mixing

The right mixing equipment is needed to ensure that the screed acts properly when it is laid, generic cement mixers are not sufficient to do this job. If mixed incorrectly the screed might have unwanted sand pockets within it, it could be hollow or too weak and might crack or curl on the surface.

Too much liquid in the screed will also negatively affect vapour transmission control. If moisture vapour below the screed cannot evaporate out of the floor and gets trapped it will lead to unsightly blistering in the floor surface.

## DPM and Insulation Layers

Installations that require a damp proof membrane, thermal insulation or acoustic insulation need to ensure that the extra layer is laid correctly.

It is important to correctly fold, lap and tape damp proof membranes to avoid cracking. Unwanted folds in the layer will act as crack inducers and lead to splits being visible in the screed surface.

Other crack inducers include conduits or trunking that may be applied above the DPM as well as any gaps that occur in layers of insulation.

## Compaction

During installation the applicators will compact the screed. Failure to compact the mixture properly will lead to a weak screed with voids (pockets of air) within it.

Especially thick screeds of around 150 mm should be applied in two layers to aid compaction. If it is all laid at once it won't compact effectively, so half will be laid and compacted and then the process repeated.

### Crack Inducement Joint

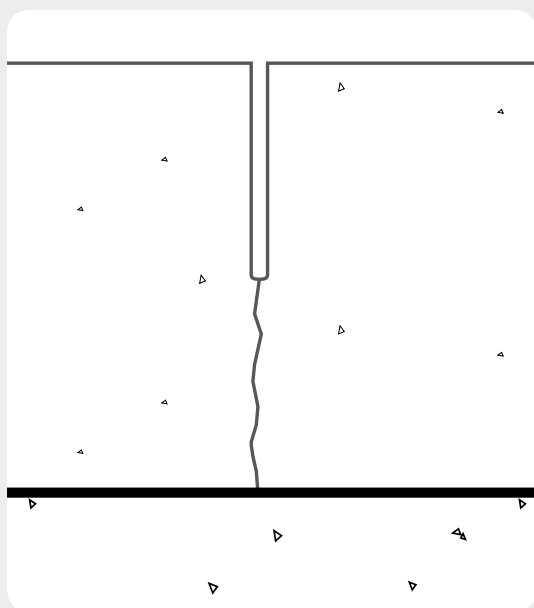

≈ 1/3–1/2 of screed depth  
Encourages uniform crack

## Curing

Once the screed has been installed on the floor it must be allowed to cure for a set period, which can differ between screeds and thicknesses. A K-screed for example needs to be cured under polythene for a week.

During the curing process the screed needs to remain covered so that the moisture stays in the screed. If the water evaporates too quickly then it won't cure and have the strength to avoid substantial shrinkage.

## Drying

After the curing period the screed needs to be dried properly. The given time it takes to dry a screed is measured to when it reaches 75% relative humidity and traditionally it takes a day per millimetre to dry. Flowcrete screeds are formulated to dry at much faster rates, for example K-screed requires roughly 7 days per 25 mm.

Faster drying products are ideal for speeding up the time of a project as next stages of construction stages can start much earlier in the schedule.

Drying rates can be subject to the conditions on site, with ventilation and air humidity being key factors, as if the environment is too wet it can delay the drying of the screed.

Significant problems can occur if there is nowhere for moisture to escape to during drying. If the humidity underneath the screed's cover reaches 100% then it won't dry until the moisture level is reduced. Common reasons for this might be that all the windows have been closed, or if contractors on the site are creating a wet environment.

If the screed has not sufficiently dried and the finish is put on top then ripples will appear in

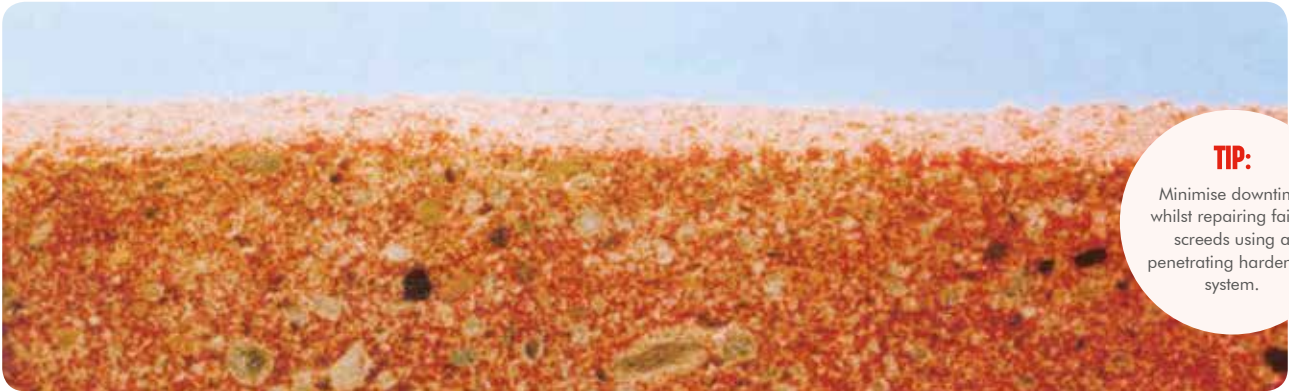

**TIP:**

Minimise downtime whilst repairing failed screeds using a penetrating hardening system.

the floor. This will happen because the screed will continue to dry and shrink underneath, disrupting the finish above it.

The screed needs to be carefully protected during this stage. Contractors in the building need to be made aware that they cannot walk or drive vehicles over the floor whilst it is drying.

## Shrinkage

Drying is the stage at which shrinkage will occur. All screeds will shrink as the moisture leaves the system, however it is the extent to which it shrinks that needs to be understood as if it shrinks too much cracks will appear.

Stress control joints should be put into the screed mixture to control cracking during the shrinking. These prevent random cracking and can be infilled once the screed has finished drying.

Stress control joints can also be used to avoid cracks from the concrete substrate moving. By lining up the joints in the concrete slabs with corresponding joints in the screed it will move with the substrate instead of cracking.

Shrinkage is a particular issue with unbonded or floating screeds because they are freer to move than screeds that have been bonded directly to the concrete. To counter this reinforcement must be placed throughout the screed.

Floating and unbonded installations with Flowcrete systems are reinforced using polypropylene (PP) fibres that are sprinkled throughout the mixture to bind it together and reduce the danger of shrinkage.

The risk of shrinkage in bonded systems is much lower and so they don't require reinforcement.

## Testing

There are a number of tests that can be applied to ascertain the effectiveness of a screed once it has been laid on site which are covered by the legislation found in the British Standard BS 8204-1. These tests will identify any problems in the finished screed.

A key examination is the in-situ crushing resistance (ISCR or drop hammer) test, in which a 4kg weight is dropped onto the floor using a particular apparatus. The dent in the ground is measured to ascertain the robustness of the finished screed.

Isocrete K-Screed is checked by the British Board of Agreement (BBA) who check that the claims of the products stand up to scrutiny with full technical investigations and regular visits to old and new installations.

## Repair

There are a number of remedial measures that can be used to repair screed failures, which can range from patch maintenance on small areas to working on problems that range across the whole screed installation.

If there is time it can be best to take off the previous screed and replace it with a new one, although this is hard to do if the time constraints of the construction project are too tight.

A penetrating hardening system (PHS), an epoxy material, is very versatile and ideal for fixing cracks, splits and flaws in a screed. It is applied over the top of the problem, soaks into the screed and hardens overnight, making it a very quick and effective solution.

The use of PHS can be a costly solution, so depending on the project sometimes it is more cost effective to remove the failed screed and apply a new one – but this is a decision which must be made on the individual specifics of the project.

Old floors that have failed can be treated with PHS to re-strengthen the screed layer, avoiding the need to relay a new screed.

***This guide has been produced to give an overview of the reasons for screed failure in both commercial and industrial environments, as well as an insight into screed failure avoidance and repair.***

***Detailed recommendations and advice are available from our network of regional technical and sales representatives.***

---

Find out more information about Flowcrete's specialist flooring solutions...



[www.flowcrete.ae](http://www.flowcrete.ae)



[uae@flowcrete.com](mailto:uae@flowcrete.com)



+971 4 347 0460